

## EURO FST

The Euro FST 600 is the perfect solution for irregular or difficult to flow products. With a top-seal film reel, this special flow wrapper can be manually or automatic fed, laying the products directly onto the film. This machine is also indicated for modified atmosphere (MAP) applications such as cheese or meat. The EURO FST range of machines also includes the following versions: intermittent motion with jaws driven by pneumatic cylinders or servomotor and the box motion machine for higher speed.



- Performances up to 25 bpm intermittent / 80 bpm box motion version
- Stainless steel structure
- Products directly onto the film to ease transportation
- Brushless motorization



## Technical Data

Max mechanical speed	Up to 25 bpm
Reel's max external Ø	350 mm / 13,78"
Reel's max width	600 mm / 23,62" (720 mm / 28,34" upon request)
Product's max height	180 mm / 7,08"
Packaging materials	Polypropylene, coupled, metallized, pearled and cold seal films
Recipes	40
Interface	7,7" color touch screen
Electrical supply	380V, 3P + N + G (other upon request)
Installed power	8 kW
Structure's material	Stainless steel AISI 304
Weight	~ 700 kg

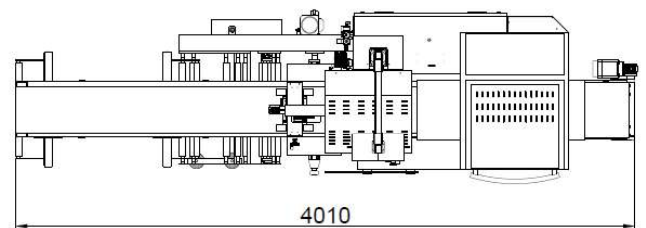
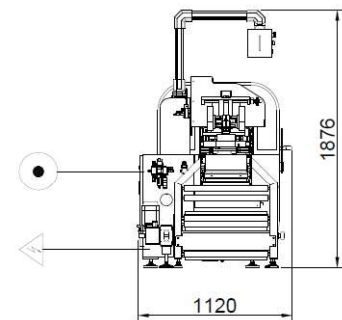
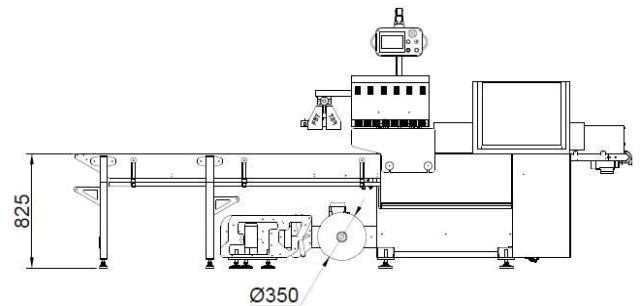

## Options

- Euroslot
- No Product - No Bag
- Reel holder with pneumatic expansion
- Printer
- Remote connection device
- Manual cutting height adjustment
- Motorized film unwinding system
- Kissing belt
- In-Out pressure device
- Lowered jaws'/wheels' seal
- Loading conveyor elongation
- Pre-heating for the first pair of wheels  
(recommended for speeds higher than 10 m/min.)

Pictures of packed products are not of promotional nature, but meant to stand as examples of different packaging types. Not all represented products were packed by Sigitaspak s.r.l.

